

JetNet 6059G / 6059G-w

Industrial 9-port Gigabit Managed Ethernet Switch



Industrial 5G
Fiber Switch



CE FC RoHS

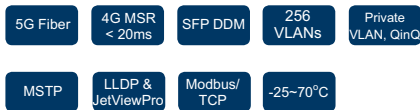

- 4 Gigabit copper ports, 5 Gigabit copper/SFP combo ports to extend Giga Copper/Fiber uplink or redundant Ring connection
- SFP ports support 100/1000 Fiber with Digital Diagnostic Monitoring (DDM) to monitor long distance fiber quality
- Independent SFP Link speed indication
- 32G bps switch Fabric, 8K MAC address to ensure High Quality Data transmission
- Isolated RS-232 Console port for negative power system
- Korenix MSR pattern aggregates up to 4 x 1000M Rings for critical data stream redundancy
- Supports LLDP and optional JetView Pro i²NMS software for network auto-topology visualization and efficient group management
- Supports Modbus TCP/IP for Factory Automation
- Advanced management by LACP/256 VLANs/GVRP/QoS/IGMP Snooping/Rate Control/ Online Multi-Port Mirroring/DHCP option 82
- Advanced Security system by Port Security, Access IP list, SSH and HTTPS Login
- Event Notification through E-mail, SNMP trap and SysLog
- Cisco-Like CLI, Web, SNMP, RMON for network Management
- Dual redundant 10.5~60VDC power inputs for system reliability
- Hi-pot isolation and -25~70°C (JetNet 6059G), -40~75°C (JetNet 6059G-w) operating temperature for harsh environments

Overview

JetNet 6059G series is an Industrial Gigabit Managed Ethernet Switch with 9 full gigabit ports and 32G switching backplane to ensure high quality data transmission in industrial applications requiring high-bandwidth connectivity. In addition to 4 Giga RJ-45 ports, the switch is equipped with 5 Giga RJ-45/SFP combo ports to deliver maximum throughput and flexibility for high-density connection while providing Giga uplink or Giga Ring connection. With the Korenix patented MSR technology, users can aggregate up to 4 MultiGigaRings into a single switch and ensure network reliability in applications with increased bandwidth and expended

system. Furthermore, JetNet 6059G supports advanced management and security features, such as LLDP and JetViewPro, 4 QoS, 256 VLAN, IGMP Snooping, DHCP, LACP to ensure high performance network communication. The supported Modbus TCP/IP protocol makes the switches suitable for factory automation systems while offering enhanced connectivity and easier network maintenance. JetNet 6059G provides dual redundant 10.5~60VDC power inputs and -40~75°C wide operating temperature range to work reliably under vibrating and shock environments in maritime, railway or rolling stock applications.

Flexible Combo ports for Enhanced Performance

JetNet 6059G offers five Gigabit RJ-45/SFP combo ports which provide various types of speed modes with flexible connectivity, including 100Mbps Single-mode/Multi-mode or 1000Mbps Single-mode/Multi-mode fiber, as well as copper connections.

System integrators can configure the switch with as many as 10 different combinations for a variety of gigabit cabling types and distances depending on their specific automation applications.

100/1000Mbps DDM SFP Transceiver for High Quality Monitoring

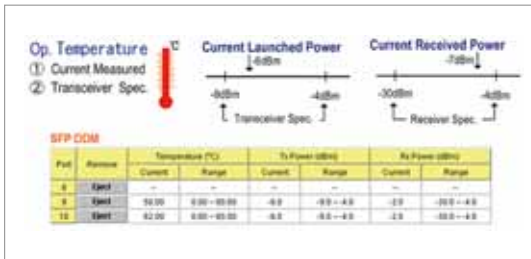

The JetNet 6059G SFP socket supports 100Base-FX single-mode/multi-mode and 1000 Base-FX single-mode/multi-mode transceiver with speed detection and independent indication. Moreover, it supports DDM (Digital Diagnostic Monitoring) type SFP transceivers allowing users to diagnose optical cable transmission problem through maintenance and debugging of the optical signal quality by DDM without the need of an extra optical cable analyzer, as a result greatly saving time and system costs.

Isolated Communication Interface with device protection

In field site application, the immunity ability is of a great importance for network communication. For this reason, some of applications are using negative power system to prevent the electrical magnetic interference. However, this is an ideal design and cannot be compatible with control device- PC as a result leading to a burn out of the serial interface. To avoid a similar damage, the power and signal circuits of JetNet 6059G's serial interface are designed with isolation which provides excellent ESD, surge and insulation protection features ensuring the system safety, reliability while keeping users out of danger.

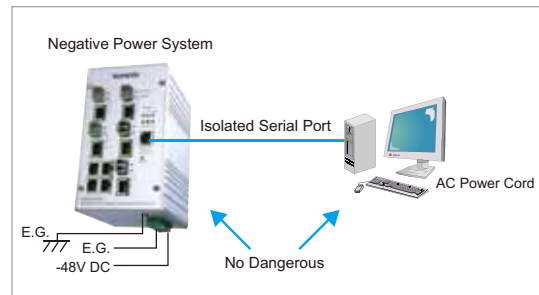

- Industrial Intelligent NMS
- Rackmount PoE Plus Switch
- Industrial PoE Plus Switch
- Industrial 12-24V PoE Switch
- Industrial PoE Switch
- Rackmount L3/L2 Switch
- Gigabit Managed Switch
- Managed Ethernet Switch
- Entry-level Switch
- Wireless Outdoor AP
- Embedded PoE/Router Computer (LINUX)
- Industrial Communication Computer (WIN/LINUX)
- Ethernet/PoE/ Serial Board
- Ethernet I/O Server
- Media Converter
- Serial Device Server
- SFP Module
- Din Rail Power Supply

Comprehensive Redundant Solutions – Multiple Super Ring (MSR™)

The JetNet 6059G supports new generation ring technology - MSR™ (Multiple Super Ring), which includes various new technologies for different network redundancy applications and structures. The JetNet 6059G allows aggregating up to 4 Gigabit Ethernet Rings. With the MSR™ technology, a node can be configured to multiple rings with the failover time in as little as 20ms and zero-second of restoration time. In addition, users can extend the ring topology by adding hundreds of JetNet series to meet the large-scale network needs without compromising the network speed.

The MSR™ also allows the JetNet series to easily connect with core management switches via standard Rapid Spanning Tree Protocol or through multiple paths or nodes to increase the reliability by RDH™ (Rapid Dual Homing) technology. By integrating MSR™ and Link Aggregation Control Protocol (LACP) the JetNet series can enhance the link availability and increase the overall link capacity. Two or more Fast Ethernet connections are combined in order to increase the bandwidth and to create a resilient and redundant link.

MSR™ Multiple Super Ring

Rapid Super Ring	Rapid Dual Homing	MultiRing	TrunkRing
<ul style="list-style-type: none"> ■ Ring Master auto-select ■ Seamless restoration ■ Ring Failure alarms/LED ■ Failed ring port together with Ring Master ■ Millisecond Recovery Time ■ Backward compatible with legacy Super Ring 	<ul style="list-style-type: none"> ■ Multiple Uplink Paths ■ One to One upper, Many to One upper, One to Many upper switches ■ Seamless Restoration ■ Korenix Patent protected 	<ul style="list-style-type: none"> ■ Couple 2 rings with shared unit ■ Multiple up to 4 Gigabit 100M Rings ■ Korenix Patent protected 	<ul style="list-style-type: none"> ■ Integrate Port Trunk/LACP with MSR, RSR ■ Load balancing of ring Ports ■ Backup with each other ■ Korenix Patent protected

Rapid Super Ring (RSR™) Technology

Rapid Super Ring is the 2nd generation of Korenix Ring Redundancy technology. The recovery time is greatly improved from 20ms to few ms for both copper and fiber rings. The Ring master can be auto-selected by RSR engine. The 1st ring port of the R.M. is the primary path while the 2nd ring port of the R.M. is the block path. Once the primary path fails, the 2nd path will be recovered within few ms. Besides, the restoration time is also shortened to zero in the R.M. auto-selection mode.

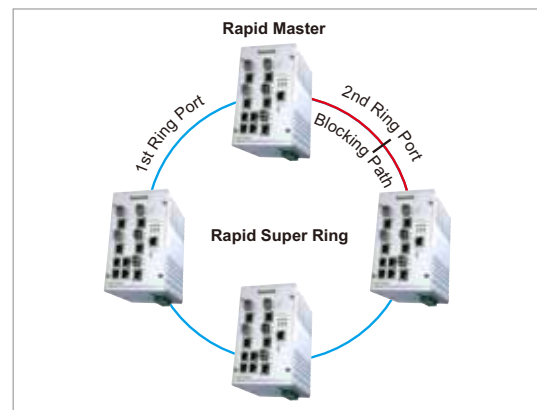

Seamless Ring Port Restoration™

Seamless restoration is a new Korenix patented technology which can restore a failed ring without causing any loop problem, topology change and

packet loss. With a 0 second restoration time, this mechanism eliminates any unstable status and guarantees the applications running non-stop.

Rapid Dual Homing (RDH™) Technology

Rapid Dual Homing is also an important feature of Korenix new generation Ring technology. It supports ring coupling with other vendors devices. Moreover, providing easy configuration and multiple redundancies, the failover time is much faster and the restoration time is zero ms. Uplinks can be auto detected and gathered into groups. In each group

uplinks are sorted into primary, secondary and standbys based on their link speed. The uplink with the highest speed is more likely to be active path for data transmission. Link aggregation is also integrated into RDH™. An uplink connection can be a single link or several links aggregated as a trunk, which provides better redundancy and link capacity.

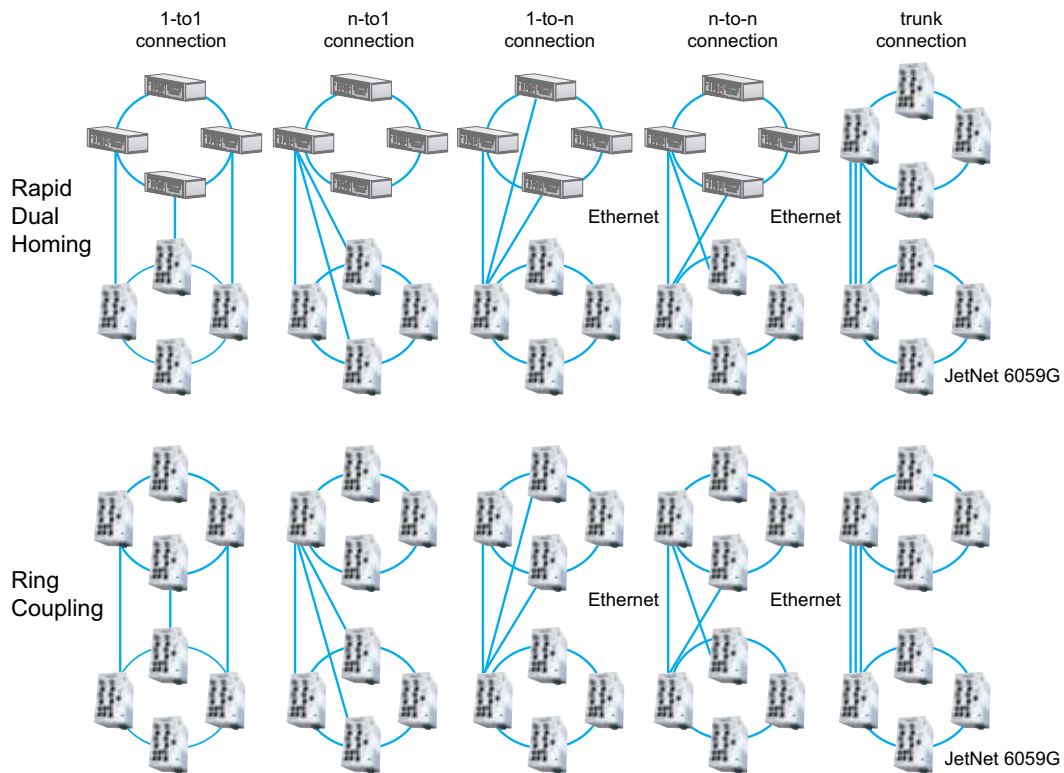

- Industrial Intelligent NMS
- Rackmount PoE Plus Switch
- Industrial PoE Plus Switch
- Industrial 12-24V PoE Switch
- Industrial PoE Switch
- Rackmount L3/L2 Switch
- Gigabit Managed Switch
- Managed Ethernet Switch
- Entry-level Switch
- Wireless Outdoor AP
- Embedded PoE/Router Computer (LINUX)
- Industrial Communication Computer (WIN/LINUX)
- Ethernet/PoE/Serial Board
- Ethernet I/O Server
- Media Converter
- Serial Device Server
- SFP Module
- Din Rail Power Supply

TrunkRing™

TrunkRing is a new feature in MSR which merges the two technologies of RSR and link aggregation. It takes advantages of aggregation to enhance the link redundancy, while increasing the link speed. The ring will open only if all the aggregated links are broken. Link aggregation can be achieved by either static trunk or LACP. Not all the link sections in a TrunkRing need to be the same. Ring links can be either symmetric or asymmetric. Some are a single path, and the others are aggregated by links where the number of links in a trunk group can be different. Users can enhance the link redundancy at different locations in accordance to the need. The link with less speed is more likely to be used as the backup path for restoring the network to full play capacity.

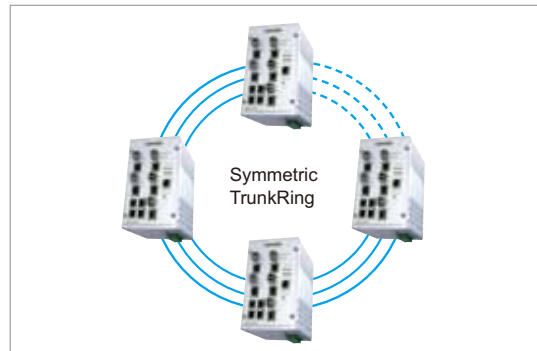
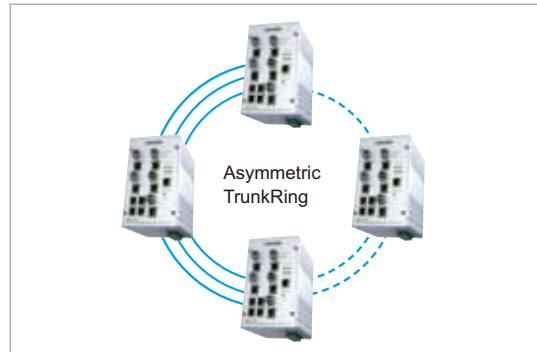

MultiRing™

The MultiRing™ provides easier connectivity between two ring networks. The simplest example is to connect two rings by a single device. Depending on the number of ports and the speed, the JetNet 6059G can even gather multiple JetNet series managed switch/e.g. JetNet 5010G rings together with gigabit connectivity. As shown in the below figure, MultiRing™ technology simply extends the network topology by linking multiple rings

into a line or into multiple directions. In addition to extensibility, MultiRing™ has great diversity of various ring technologies. When MultiRing™ enabled, JetNet 6059G can connect RSR rings, TrunkRing™ and a Super Ring together and simultaneously provide more Gigabit Ethernet Ring connectivity. This provides extensibility to new technologies while keeping the great backward compatibility.

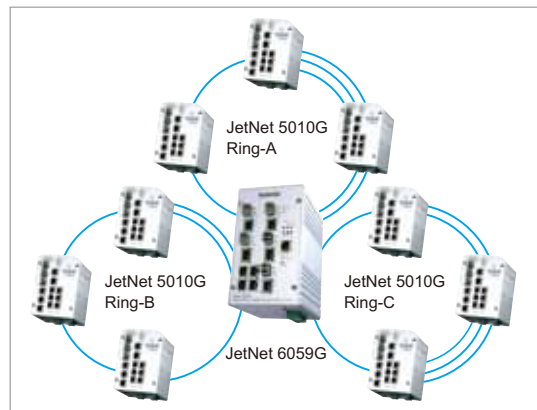
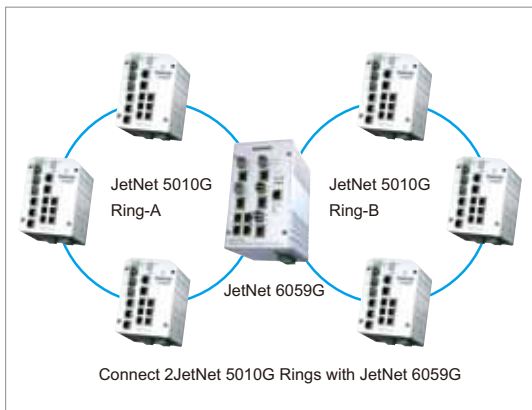

Link Aggregation Control Protocol

Link Aggregation Control Protocol allows users grouping multiple Ethernet ports in parallel to increase the link bandwidth. The aggregated ports can be viewed as one physical port, so that the bandwidth is higher than just one single Ethernet port. The member ports of the same trunk group can balance the loading and backup with each other. The LACP feature is usually used when higher bandwidth is needed for the backbone network. This is a cost-effective way for transferring much more data. If the trunk port is also assigned as a ring port, it will become a TrunkRing, which means the bandwidth of ring path has increased with port trunk technology. Now, there is no recovery time when failure occurred. The JetNet 6059G provides a simple and easy way to aggregate port bandwidth into Rapid Super Ring.

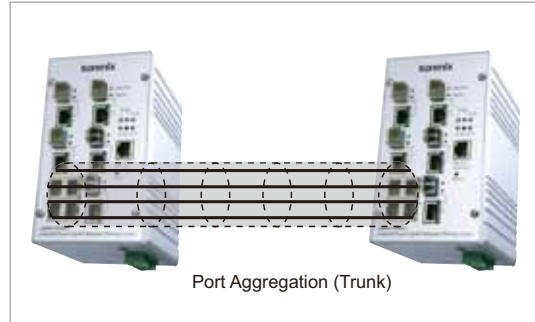

- Industrial Intelligent NMS
- Rackmount PoE Plus Switch
- Industrial PoE Plus Switch
- Industrial 12-24V PoE Switch
- Industrial PoE Switch
- Rackmount L3/L2 Switch
- Gigabit Managed Switch**
- Managed Ethernet Switch
- Entry-level Switch
- Wireless Outdoor AP
- Embedded PoE/Router Computer (LINUX)
- Industrial Communication Computer (WIN/LINUX)
- Ethernet/PoE/Serial Board
- Ethernet I/O Server
- Media Converter
- Serial Device Server
- SFP Module
- Din Rail Power Supply

IEEE 1588 Precision Time Protocol (PTP)

The Precision Time Protocol is designed to synchronize time across Ethernet networks. It allows synchronization of distributed clocks to sub-microsecond accuracy for devices that may have differing precision, resolution and stability. JetNet 6059G supports Auto (or bindery clock), Master and Slave modes for time synchronization to achieve

a high level of synchronization within an industrial motion-control environment with a minimum use of network and computing resources. The protocol helps for sequencing event measurements, scheduling outputs, synchronizing actuation, time-stamping, coordinating event records, etc.

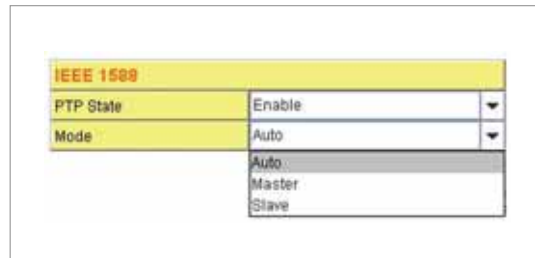
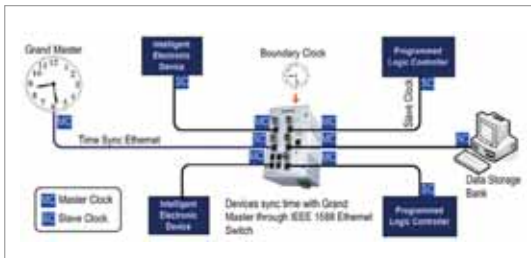

Auto Topology Discovery & Efficient Management through LLDP and JetView Pro i²NMS

JetNet 6059G supports topology discovery or LLDP (IEEE 802.1AB Link Layer Discovery Protocol) function that can help users to discover multi-vendor's network devices on the same segment by an NMS system, which support LLDP function. With LLDP function, NMS can easily maintain the topology map, display port ID, port description, system description, VLAN ID, etc.. Once a link failure happens, the topology changed events are updated to the NMS to help users easily maintain the network system. Besides the SNMP and LLDP protocols, JetNet 6059G series efficiently works with the Korenix patented JetView Pro i²NMS, which in addition to the auto-topology discovery, also delivers MSR™ group management, group IP assignment, firmware upgrade, configuration file backup/ restore ,SNMP MIB Browser /compile, etc. Furthermore, users can export the topology map to diverse formats,

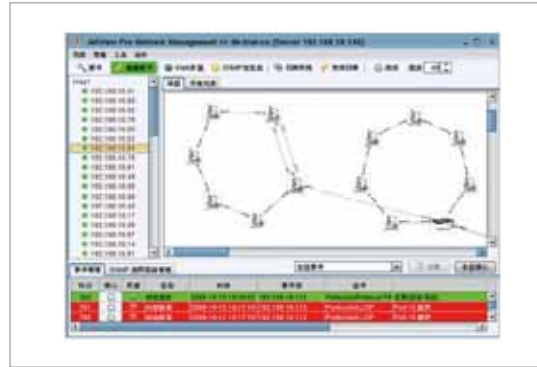

such as JPG, BMP, PNG and PDF, for easily managing and trouble-shooting the network. The user-friendly software allows administrators to discover devices automatically and efficiently manage the performance of the industrial network.

Outstanding Management and Enhanced Security

The JetNet 6059G provides various network control and security features to ensure the reliable and secure network connection. To optimize the industrial network environment, the switch supports advanced network features, such as Tag and Port-based VLAN, IGMP Snooping, Quality of Service (QoS), Link Aggregation Control Protocol (LACP), Rate Control, etc. The PoE switch can be smartly configured through JetView, JetView Pro (Korenix's advanced management utility), Web Browser, SNMP, Telnet and RS-232 local console with its command

like interface. The failure notifications are sent through e-mail, SNMP trap, Local/Remote system log, Fault event alarm relay. Furthermore, the built-in watchdog timer of JetNet 6059G allows users to recover system when CPU failure is detected. To avoid hacker's attacks and ensure the secure data transmission, JetNet 6059G series features DHCP client, DHCP server with IP and MAC binding, 802.1X Access Control, SSH for Telnet security, IP Access table, port security and many other security features.

Rugged Design for Harsh Environments

The JetNet 6059G, compliant with the electromagnetic conformance requirements of Maritime industry, provides a high level of electromagnetic susceptibility exceeding the Railway, Traffic control and Heavy-industrial standards' requirements with distinguished surge protection.

Equipped with a rugged aluminum case with high thermal-conductivity design, it is capable of resisting -25~70°C (JetNet 6059G) and -40~75°C (JetNet 6059G-w) wide temperature ranges while providing reliable connectivity under harsh industrial environments.

Modbus TCP/IP for Factory Automation Network Enhancement

The Modbus TCP/IP protocol is supported in JetNet 6059G series for factory automation applications. It enables administrator to connect to data acquisition (SCADA) system and read the switch's operating information using its own Modbus TCP/IP master program for monitoring and maintaining switch's status. With the supported Modbus TCP/IP, the JetNet 6059G series become an element of factory automation such as the Programmable Logic Controller (PLC), Distributed Control System (DCS), and allow users to monitor/maintain factory equipment on the HMI (Human Machine Interface) system, including production information and communication status. Therefore, user does not need to integrate multiple management platforms to

monitor factory equipment: with just a single JetNet 6059G platform users can easily achieve enhanced monitoring and maintenance of the entire factory.

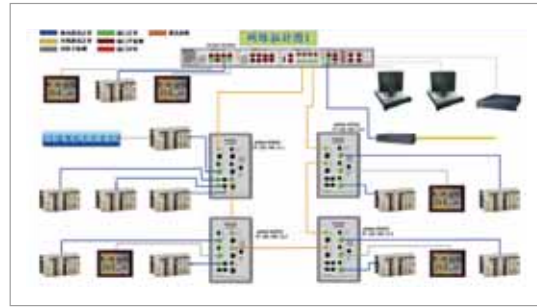

- Industrial Intelligent NMS
- Rackmount PoE Plus Switch
- Industrial PoE Plus Switch
- Industrial 12-24V PoE Switch
- Industrial PoE Switch
- Rackmount L3/L2 Switch
- Gigabit Managed Switch**
- Managed Ethernet Switch
- Entry-level Switch
- Wireless Outdoor AP
- Embedded PoE/Router Computer (LINUX)
- Industrial Communication Computer (WIN/LINUX)
- Ethernet/PoE/Serial Board
- Ethernet I/O Server
- Media Converter
- Serial Device Server
- SFP Module
- Din Rail Power Supply

Dimensions (Unit = mm)

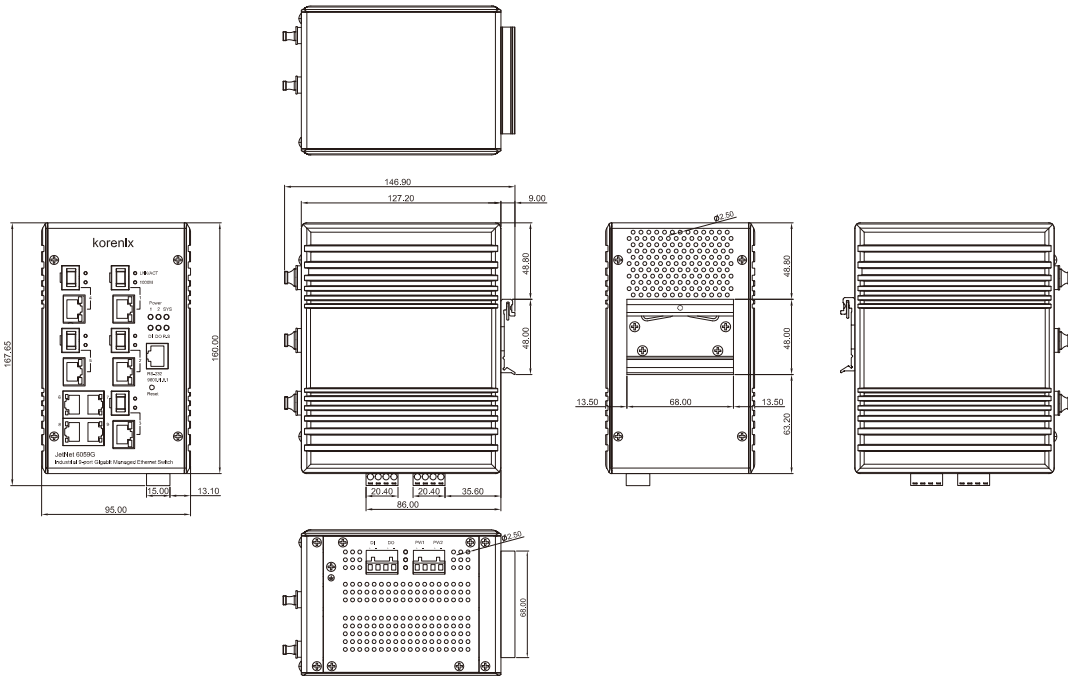

Specification

Technology

Standard:

IEEE 802.3 10Base-T Ethernet
 IEEE 802.3u 100Base-TX Fast Ethernet
 IEEE 802.3u 100Base-FX Fast Ethernet Fiber
 IEEE 802.3ab 1000Base-T
 IEEE 802.3z Gigabit Fiber
 IEEE 802.3x Flow Control and Back-pressure
 IEEE 802.1AB Link Layer Discovery Protocol (LLDP)
 IEEE 802.1p Class of Service (CoS)
 IEEE 802.1Q VLAN and GVRP
 IEEE 802.1QinQ
 IEEE 802.1D-2004 Rapid Spanning Tree Protocol (RSTP)
 IEEE 802.1s Multiple Spanning Tree Protocol (MSTP)
 IEEE 802.3ad Link Aggregation Protocol (LACP)
 IEEE 802.1x Port Based Network Access Protocol
 IEEE 1588 Precision Time Protocol (PTP)
 Modbus TCP/IP

Performance

Switch Technology: Store and Forward Technology with 32Gbps Switch Fabric.

System Throughput: 26 Mega packets per second, 64 bytes packet size.

14,880pps pps for 10Base-T

148,800pps for 100Base-TX/FX

1488,100pps for 1000Base-T/ Gigabit fiber

Maximum packet size up to 1632bytes

CPU performance: 32 bits ARM-9E running at 180 Mhz and performance up to 200MIPS; Embedded hardware based watch-dog timer.

System Memory: 8M bytes flash ROM, 64M bytes SDRAM.

Transfer packet size: 64 bytes to 1632 bytes (includes 1522 bytes VLAN Tag).

MAC Address: 8K

Packet Buffer: 1M bits shared memory for packet buffer

Transfer performance: 14,880pps for Ethernet and 148,800 for Fast Ethernet, 1488,100 for Gigabit Ethernet

Thermal Monitoring: Embedded board-level thermal detector for main-chip temperature monitoring

Relay Alarm: Dry Relay output with 1A/30V DC or 0.5A/125V AC ability.

Digital Input (DI):

One Digital Input with Photo Copular isolation

Digital High: DC 11V~30V

Digital Low: DC 10V~0V

System Management

Configuration and monitoring interface: Supports 4 configuration and monitoring interfaces: RS-232 serial port, Telnet, SNMP and Web Browser interface
 The RS-232 and Telnet interfaces support Cisco like instructions

System upgrade/Backup: Provides TFTP/Web interface for firmware upgrade and configuration backup, restore

Telnet & Local Console: Supports command line interface with Cisco like commands and maximum 4 sessions; the telnet interface also supports SSH

SNMP: Supports v1, v2c, V3 with SNMP trap function, trap station up to 4 and can be manually configured the trap server IP address

SNMP MIB: MIBII, Bridge MIB, Ethernet-like MIB, VLAN MIB, IGMP MIB, Korenix Private MIB

Korenix Utility: Supports JetView and JetView Pro with IEEE 802.1AB Link Layer Discovery Protocol for device finding and link topology discovery

Network Time Protocol: Supports NTP protocol with daylight saving function and localize time sync function.

Management IP Security: IP address security to prevent unauthorized access

E-mail Warning: 4 receipt E-mail accounts with mail server authentication

System Log: Supports both Local or remote Server with authentication

Modbus TCP/IP: Supports open protocol - Modbus TCP/IP with function code group -4 for factory automation application.

Network Performance

IEEE 802.3x: Flow control pause frame supports on 10/100/1000Mbps Full Duplex and Back-pressure supports on 1000Mbps Half Duplex only

Port Configuration: port link speed, link mode, port status, enable/disable

Port Trunk: IEEE 802.3ad LACP with timer and static port trunk; trunk member up to 8 ports and maximum 4 trunk groups include Gigabit Ethernet port

VLAN: IEEE 802.1Q Tag VLAN with 256 VLAN Entries and provides 2K GVRP entries; 3 VLAN link modes- Trunk, Hybrid and Link access

Private VLAN: Direct client ports in isolated/community VLAN to promiscuous port in primary VLAN

IEEE802.1 QinQ: Supports Double VLAN Tag function for implementing Metro Network topologies

Class of Service: IEEE 802.1p class of service; per port 4 priority queues.

Traffic Prioritize: Supports 4 physical queues, weighted run robin queuing (WRR 8:4:2:1) and Strict Priority scheme, which follows 802.1p COS tag and IPv4 ToS/ Diffserv information to prioritize the traffic of your industrial network.

IGMP Snooping: IGMP Snooping v1/v2 /v3 for multicast filtering and IGMP Query mode; also support unknown multicasting process forwarding policies- drop, flooding and forward to router port.

Rate Control: Ingress filtering for Broadcast, Multicast, Unknown DA or all packets. Egress filtering for all packet types.

Port Mirroring: Online traffic monitoring on multiple selected ports

Port Security: Port security to assign authorized MAC to specific port

DHCP: DHCP Client, DHCP Server with IP & MAC Address binding and DHCP agent (option 82).

IEEE 802.1X with Radius control: Port based network access control and also supports user authenticate by the radius account, password and key for the radius server authentication

Network Redundancy

Multiple Super Ring (MSR™): New generation Korenix Ring Redundancy Technology, Includes Rapid Super Ring, Rapid Dual Homing, TrunkRing™, MultiRing™ and backward compatible with legacy Super Ring™; up to 20ms recovery time on fiber port

Rapid Dual Homing (RDH™): Multiple uplink paths to one or multiple upper switch

TrunkRing™: Integrate port aggregate function in ring path to get higher throughput ring architecture

MultiRing™: Couple or multiple up to 16 Rapid Super Rings, JetNet 6059G supports up to 4 Gigabit Ring in one Switch

Rapid Spanning Tree: IEEE802.1D-2004 Rapid Spanning Tree Protocol. Compatible with Legacy Spanning Tree and IEEE 802.1w

Multiple Spanning Tree: IEEE802.1s MSTP, each MSTP instance can include one or more VLANs.

Interface

Enclosure Port:

10/100/1000TX: 9 x RJ-45 Fast Ethernet

Gigabit Fiber: 5 x SFP socket

RS-232 interface: RJ-45 connector

Alarm Relay, Digital Input: 4 pin removable terminal block

Power connector: 4-pin removable terminal block

Cables: 10Base-T: 2-pair UTP/STP Cat. 3, 4, 5 cable,

EIA/TIA-568B 100-ohm (100m)

100 Base-TX: 4-pair UTP/STP Cat. 5 cable,

EIA/TIA-568B 100-ohm (100m)

1000 Base-T: 4-pair UTP/STP Cat. 5e, 6 cable,

EIA/TIA-568B 100-ohm (100m)

RS-232 serial interface: Isolated serial interface

LED Indicators: 10/100/1000 RJ-45 port: Link (Green on) /

Activity (Blinking), 1000Mbps (Yellow on)

SFP port: Link (Green on)/Activity (Blinking),

1000Mbps (Yellow on)

System Power: Power on (Green on)

Alarm Relay Output: Relay Activate (Red on)

Digital Input: Signal input (Green on)/No signal (Green off)

System Status: System ready (Green on) /

Indication (Green Blinking)

Ring Status: Green on (Ring normal) / Blinking (Ring with wrong port), Yellow on (Ring abnormal) / Blinking (device's ring port failed)

Power Requirements

System Power: 2 power inputs with redundancy and polarity reverse protection; supports positive/negative power system

Input voltage: DC24V, range 10.5~60V

Power Consumption: 24Watts / DC 24V

Mechanical

Installation: DIN Rail or Wall Mounting

Case: Aluminum metal case with IP31 grade protection

Dimension:

95 x 160 x 136 (W x H x D) / with DIN Rail Clip

95 x 160 x 127.2 (W x H x D) / without DIN Rail Clip

Weight: 1440g without package

Environmental

Operating Temperature: -25 ~ 70°C (JetNet 6059G)

-40 ~ 75°C (JetNet 6059G-w)

Operating Humidity: 0% ~ 95% (non-condensing)

Storage Temperature: -40 ~ 85°C

Hi-Pot Insulation: AC 1.5KV for all ports and power

Regulatory Approvals

EMC: Compliance with the EMC standard of Heavy Industrial IEC/EN 61000-6-2, IEC/EN61000-6-4 and FCC Part 15 Subpart B

EMS: IEC 61000-4-2, IEC 61000-4-3, IEC 61000-4-4,

IEC 61000-4-5, IEC 61000-4-6, IEC 61000-4-8,

Vibration: IEC60068-2-6 ^{Note-1}

Shock: IEC60068-2-27 ^{Note-2}

Free Fall: IEC60068-2-32 with package ^{Note-3}

Warranty: Global 5 years

Note-1: available in the further version software

Note-2: pending

Note-3: Korenix's internal testing

Industrial
Intelligent
NMS

Rackmount
PoE Plus
Switch

Industrial
PoE Plus
Switch

Industrial
12-24V
PoE Switch

Industrial
PoE Switch

Rackmount
L3/L2 Switch

Gigabit
Managed
Switch

Managed
Ethernet
Switch

Entry-level
Switch

Wireless
Outdoor AP

Embedded
PoE/Router
Computer
(LINUX)

Industrial
Communication
Computer
(WIN/LINUX)

Ethernet/PoE/
Serial Board

Ethernet
I/O Server

Media
Converter

Serial Device
Server

SFP Module

Din Rail
Power Supply

Ordering Information

JetNet 6059G Industrial 9-port Gigabit Managed Ethernet Switch, 4 TX, 5 TX/SFP combo, -25~70°C operating temperature

JetNet 6059G-w Industrial 9-port Gigabit Managed Ethernet Switch, 4TX, 5TX/SFP combo, -40~75°C operating temperature

Includes:

- JetNet Switch (without SFP transceiver) x1 / Wall mounting plate x1 set
- Quick Installation Guide x1 / Documentation CD-ROM x1 / RS-232 console Cable x1

Optional Accessories

100Base-FX SFP Transceiver

100Base-FX BIDI/WDM SFP Transceiver

100Base-FX SFP Transceiver with DDM

100Base-FX BIDI/WDM SFP Transceiver with DDM

Gigabit SFP Transceiver

Gigabit SFP Transceiver with DDM

Gigabit BIDI/WDM SFP Transceiver

Gigabit BIDI/WDM SFP Transceiver with DDM